

**Targeted Constituents**

<input checked="" type="radio"/> Significant Benefit		<input type="radio"/> Partial Benefit		<input type="radio"/> Low or Unknown Benefit	
<input checked="" type="radio"/> Sediment	<input type="radio"/> Heavy Metals	<input type="radio"/> Floatable Materials	<input type="radio"/> Oxygen Demanding Substances		
<input type="radio"/> Nutrients	<input type="radio"/> Toxic Materials	<input type="radio"/> Oil & Grease	<input type="radio"/> Bacteria & Viruses	<input type="radio"/> Construction Wastes	

**Description**

Prevent or reduce the discharge of sediment as a result of construction activity by stabilizing soil, using a wide variety of geotextile materials and applications. Areas with current and potential erosion problems may also benefit from the installation of geotextiles. Geotextiles may also be used in conjunction with other construction methods or as part of a landscaped terrain to prevent potential erosion problems. This practice will create a significant reduction in sediment.

**Suitable Applications**

- Areas where disturbed soils must be stabilized on a construction project, for which erosion control matting, hydraulic mulch and other methods are not appropriate.
- Slopes steeper than 2:1 (H:V), or where the erosion hazard is high.
- Critical areas, such as streams, wetlands or other highly-valued resources needing protection.
- Channels intended to be vegetated or otherwise lined where the design flow exceeds the permissible velocity.

**Overview**

This BMP will include a discussion of various geotextiles used for typical construction projects and for erosion control applications. A related application is ES-11, Erosion Control Matting, for temporary uses involving a thin plastic mesh to contain organic materials in establishing permanent vegetation growth.

Geotextiles have filtration and separation properties that directly contribute to erosion and sediment control. Other geotextile products, by virtue of streamlining or shortening the construction process, contribute to erosion and sediment control in terms of reduced schedules or reduced excavations.

As a word of explanation, geotextiles are a particular type of geosynthetic material. Geosynthetic materials are made from long polymers of plastic substances such as polypropylene, polyethylene, polyvinyl chloride and other types, usually created from petrochemical raw materials. Geosynthetics have unique properties that are used to replace traditional materials in the construction process. Geosynthetic liners are waterproof, chemically-resistant plastic sheets that are commonly used for landfills, stream channels, holding ponds, vapor barriers, etc.

**Approach**

A geotextile is not waterproof and generally has the appearance of cloth or fabric. There are two types, woven and nonwoven, indicating how the geotextile was made. Most applications can use either woven or nonwoven geotextiles; each type has its advantages and disadvantages. Some geotextile applications may affect slope stability, bearing strength and settlement; these applications should be designed by a registered engineer in conjunction with product information from the geotextile manufacturer. Common applications are listed below; this BMP only discusses the first two items.

- **Erosion Control:** A geotextile can be installed on steep slopes or drainage channels as part of a permanent solution to sloughing soils or high flow velocities. Other types of geosynthetic materials, such as turf reinforcement mats or geocells, are briefly mentioned in this BMP as alternatives for controlling erosion.
- **Sediment Control:** A geotextile can be used as part of a silt fence, excavation dewatering system, sand filter, outlet control structure to prevent sediment from leaving a construction site. The principal geotextile property would be the size of openings in the fabric.
- **Subgrade Stabilization:** A geotextile can be placed on subgrade to help bridge loads for traffic, buildings or permanent structures. Can often be installed on muddy or soft soils as a first step in constructing a temporary access road.
- **Protection or Cushion:** A geotextile can act as a cushion during the construction process, to prevent impact damage, or as a barrier.
- **Filtration or Drainage:** A geotextile can separate two materials while still allowing water to drain in either direction. This property makes geotextiles highly desirable in the construction of subsurface drains, french drains, sand filters, retaining walls, streets and roadways, and buildings.

***Definition of Terms***

**Geotextile Filtration:** The property of a geotextile barrier that allows the passage of water while retaining the solid material on the uphill or upstream side of the barrier.

**Geotextile Separation:** The property of a geotextile barrier placed between dissimilar materials so that the integrity of both materials can remain intact or be improved.

**Nonwoven Geotextile:** Geotextiles made by extruding and spraying fibers onto a moving conveyor belt to form a continuous web which is then joined by melt-bonding, resin-bonding, or needle punching.

**Woven Geotextile:** Geotextiles made by weaving polymeric threads on a loom.

**Minimum Average Roll Value (MARV):** The minimum average value of a representative number of tests made on selected rolls of a production lot, with a minimum of a 95% confidence level as determined statistically.

**Geogrid or Geocell:** A geosynthetic material to be placed at a stream or channel location where it can be filled with soil or rock, or where it can fill with sediment, so that the geosynthetic material can reinforce the soil against movement.

**Fiber Roll:** A roll of organic material, reinforced by plastic mesh or netting, installed to capture sediment on a slope or to prevent stormwater from eroding a stream bank.

***Factors for Material Selection***

There are many types of geotextiles; selection of the appropriate type should be based on the desired need and site conditions. The following criteria should be considered in selecting a geotextile:

- Effectiveness (reducing erosion, slowing flow velocity, retaining soils)
- Engineering properties (strength, texture, weight, opening size)
- Acceptability (no environmental impacts, regulatory approval, aesthetics)
- Function (vegetation enhancement, safety, affect on wildlife)
- Maintenance (longevity, repair or replacement methods, inspection schedule)
- Costs (materials, transportation, preparation, installation, maintenance)

Geotextiles are commonly specified and categorized by weight, which allows a quick comparison on prices and performance. A lightweight geotextile typically weighs in the neighborhood of 4 to 6 ounces per square yard. A heavyweight geotextile may weigh as much as 16 ounces per square yard. However, always check properties and test values as reported on the vendor catalog or on the delivery sheet.

Geotextile properties are referenced to standards procedures or specifications by the American Society for Testing and Materials (ASTM). The chart below has commonly referenced properties to include a few methods of measuring strength. Geotextile producers monitor quality with onsite laboratories and independent third-party checks. Geotextiles are usually inert to common chemicals and hydrocarbons; they are also resistant to mildew, rot, insects and rodents.

The following list contains a typical geotextile specification for use as a separator beneath riprap or aggregate linings in drainage channels. Assumptions include that riprap will be dumped carefully onto the fabric from a height of less than 5 feet, and for non-muddy areas where the geotextile will not be driven on directly.

<b>Typical Properties for Geotextile Underneath Riprap or Aggregate</b>	
<b>Property</b>	<b>Typical values (MARV)</b>
Tensile strength (grab)	200 pounds
UV degradation at 500 hours	70%
Puncture strength	80 pounds
Burst strength	180 psi
Trapezoidal tear strength	60 pounds
Weight	6 ounces per square yard
Apparent opening size	40 to 70 (US sieve sizes)

Field joining should be accomplished by sewing for critical applications, such as flowing streams or steep slopes. A typical stitch density for nylon thread is 5 stitches per inch with either single-thread or double-thread stitching patterns.

Field joining for less critical applications may also be accomplished by overlapping and then using stakes or staples in the overlapped portions. The amount of overlap depends on the size and positioning of the stakes or staples.

### *Site Preparation*

- Proper site preparation is essential to ensure complete contact of a geotextile with the subgrade. Grade and shape the installation area. Remove all rocks, clods, vegetation or other obstructions.
- Prepare subgrade by loosening at least 2 inches of topsoil. Incorporate topsoil amendments as necessary, such as lime and fertilizer, according to soil tests, vegetation plan, and manufacturer's recommendations.

### *Delivery and Storage*

- Deliver geotextiles to the application site in rolls that are wrapped with protective coverings to prevent damage from mud, dirt, dust and debris. Inspect geotextiles to ensure that the materials are free of defects or flaws.
- Store geotextiles above the ground surface and away from potential stormwater contact. Protect materials from direct sunlight and from extreme hot or cold temperatures. Limit exposure to sunlight to a few days; ultraviolet light degrades any geosynthetic material that does not contain carbon black additives. Do not allow mud and dirt to clog geotextile fabric, thus preventing filtration or drainage.

### *Installation of Geotextiles on Slopes or Drainage Channels*

Consult manufacturer's written guidelines for installation. Typical methods and anchor guidelines are shown in Figures ES-12-1 and ES-12-2. Geotextiles are usually not difficult to handle, except that strong winds can create an uplift. Use temporary weights during placement of geotextile to prevent movement or damage. Field joining by sewing requires special equipment and expertise, so this method is not described.

Geotextiles which are to be placed permanently on long slopes or steep grades must be selected and designed by a registered engineer with appropriate experience and knowledge. Slope stability and slope failure analyses may be necessary to ensure that a geotextile will not be a potential problem, particularly in areas that could endanger people or property. Placing geotextile under a layer of soil generally creates a potential slope failure plane, which could be mitigated by terraces or structural measures.

- Install the geotextile in anchor trench at least 6 inches deep and 6 inches wide at the uphill location, or at the downstream location if in a channel. Backfill anchor trench and tamp earth firmly.
- Unroll blanket down the slope or in the upstream direction of water flow. Lay blankets loosely and maintain direct contact with the subgrade soil. Do not stretch or twist geotextile fabric. Overlap edges of adjacent parallel rolls by at least 3 inches and then stake or staple within the overlap.
- When blankets must be spliced, place blankets end over end (shingle style) with a minimum overlap of 6 inches. Install stakes or staples through overlapped area approximately 12 inches apart.
- Stake or staple geotextiles as recommended by the manufacturer for the specific application. Stagger stakes or staples rather than installing in a straight line. Use biodegradable materials whenever possible. Place initial lift of material carefully onto geotextile; avoid damage from heavy equipment blades, buckets or tracks.

***Fiber Rolls***

Fiber rolls (or fiber logs) are very similar to erosion control matting, except that they come in a different shape. Fiber rolls are installed horizontally (along a level contour) to prevent sediment from moving downhill. Fiber rolls are also useful along a stream bank or channel, to prevent damage from rising/falling water levels or from wave action. See Figure ES-12-3 for typical installation of fiber rolls or fiber logs.

Maximum spacing between rows of fiber rolls is usually 30 feet or less, depending on the slope. Typical fiber roll diameters range from 8 to 20 inches. Wood or metal stakes with a minimum length of 3 feet are needed at a typical spacing of 4 feet. The fiber roll should be entrenched into the slope or streambank a minimum of 4 inches deep, so that it will act in the same manner as a strawbale.

***Geocells and Turf Reinforcement Mats***

A geocell or geogrid, while not considered to be a geotextile, is a type of geosynthetic product that is commonly used to stabilize channel crossings or stream banks. The geocell is usually a mat consisting of hexagonal cells, possibly 4 to 6 inches across and also 4 to 6 inches deep, from a relatively thick piece of geosynthetic material. The honeycombed cells are filled with either aggregate or soil; a filled geocell typically has enough strength to support vehicle traffic.

Consult the manufacturer’s recommendations for installation of geocells or geogrids. The manufacturer will have design charts and anchor patterns based upon the application. These structures require careful installation prior to backfilling with soil and other materials.

Turf reinforcement mats (or TRMs) is not considered to be a geotextile either; they are very similar to erosion control matting (discussed in ES-11) except with stronger geosynthetic materials. A common application for TRMs is areas where sedimentation is likely to take place, such as at the bottom of slopes or in certain channel reaches.

**Maintenance**

- Installation of geotextiles shall be inspected after significant rainfalls to check for erosion and undermining. If washout or breakages occur, repair or replace geotextile immediately after repairing the damage to the slope or channel.
- Inspect fiber rolls whenever rain is forecast and perform required maintenance. Inspect fiber rolls following rainfall events and at least daily during prolonged rainfall. Repair or replace fiber rolls that are torn or unraveling.

**Limitations**

- Some slopes or channels may be difficult for heavy equipment to access, requiring substantial effort such as excavation and filling. Consider access needs early in the design phase and incorporate into design plans.
- Geotextiles may not be suitable in areas where vegetation will be mowed regularly (since stakes and netting can catch in mowers and other equipment).

**References**

**30, 31, 32, 33, 34, 35, 141, 148, 172, 179** (see BMP Manual Chapter 10 for list)

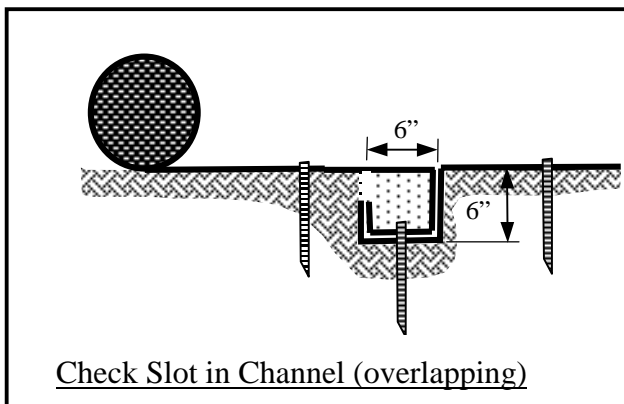
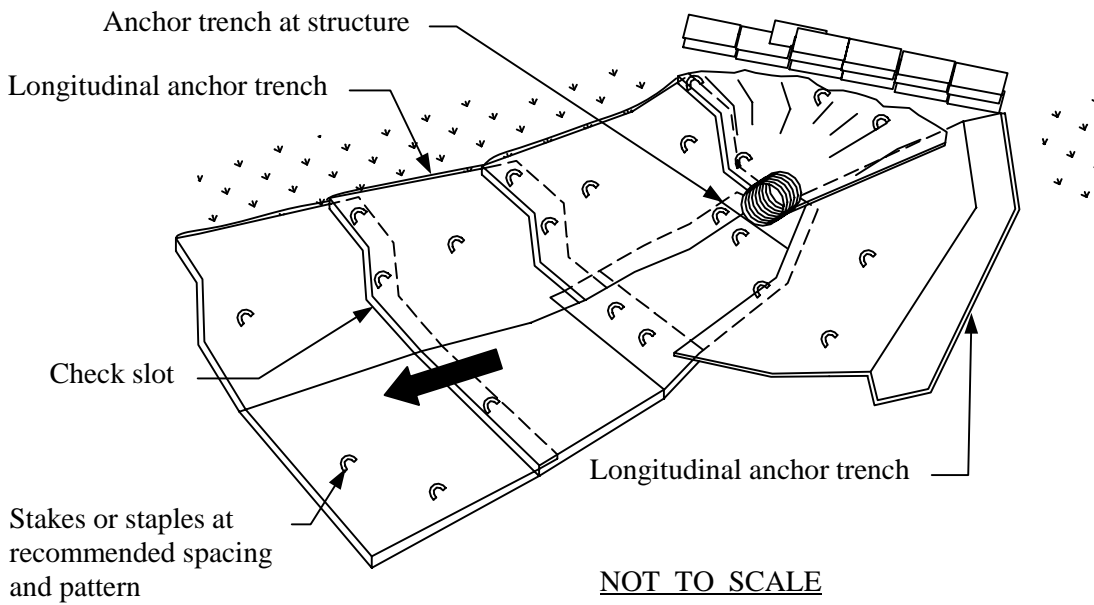
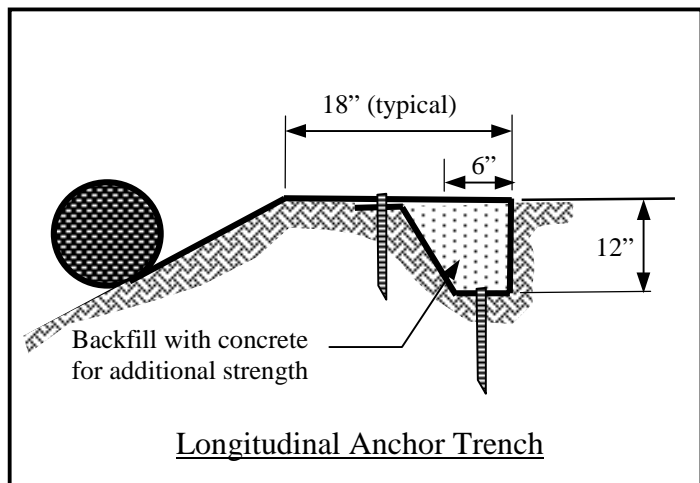
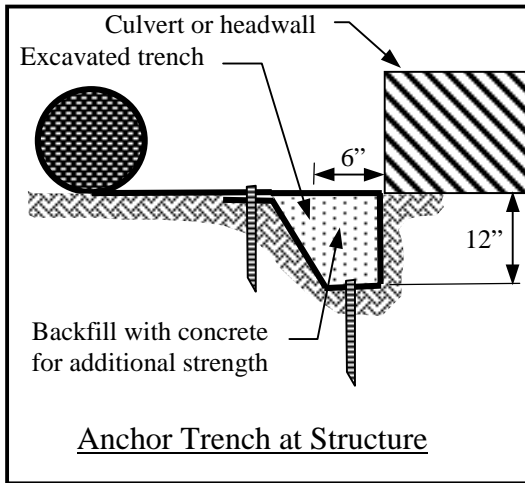

Notes:

1. Stitching geotextile seams is preferable to joints by overlapping. Consult a registered engineer for hydraulic and stability analyses for flowing streams and for steep grades.
2. Staking or stapling layout shall conform to manufacturer's recommendations for flow and grades.

**Figure ES-12-1**  
**Anchoring Geotextiles in Channels**

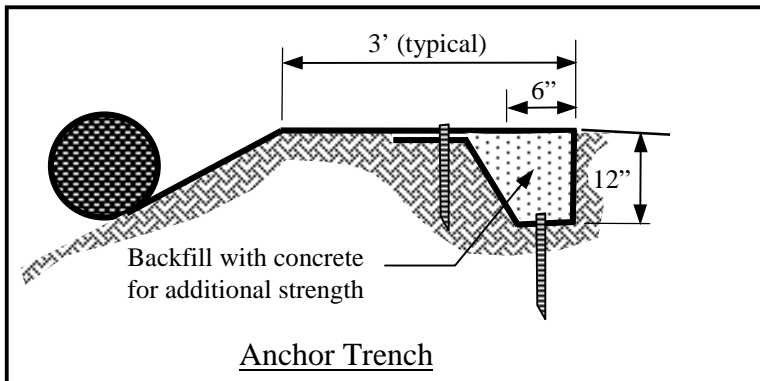
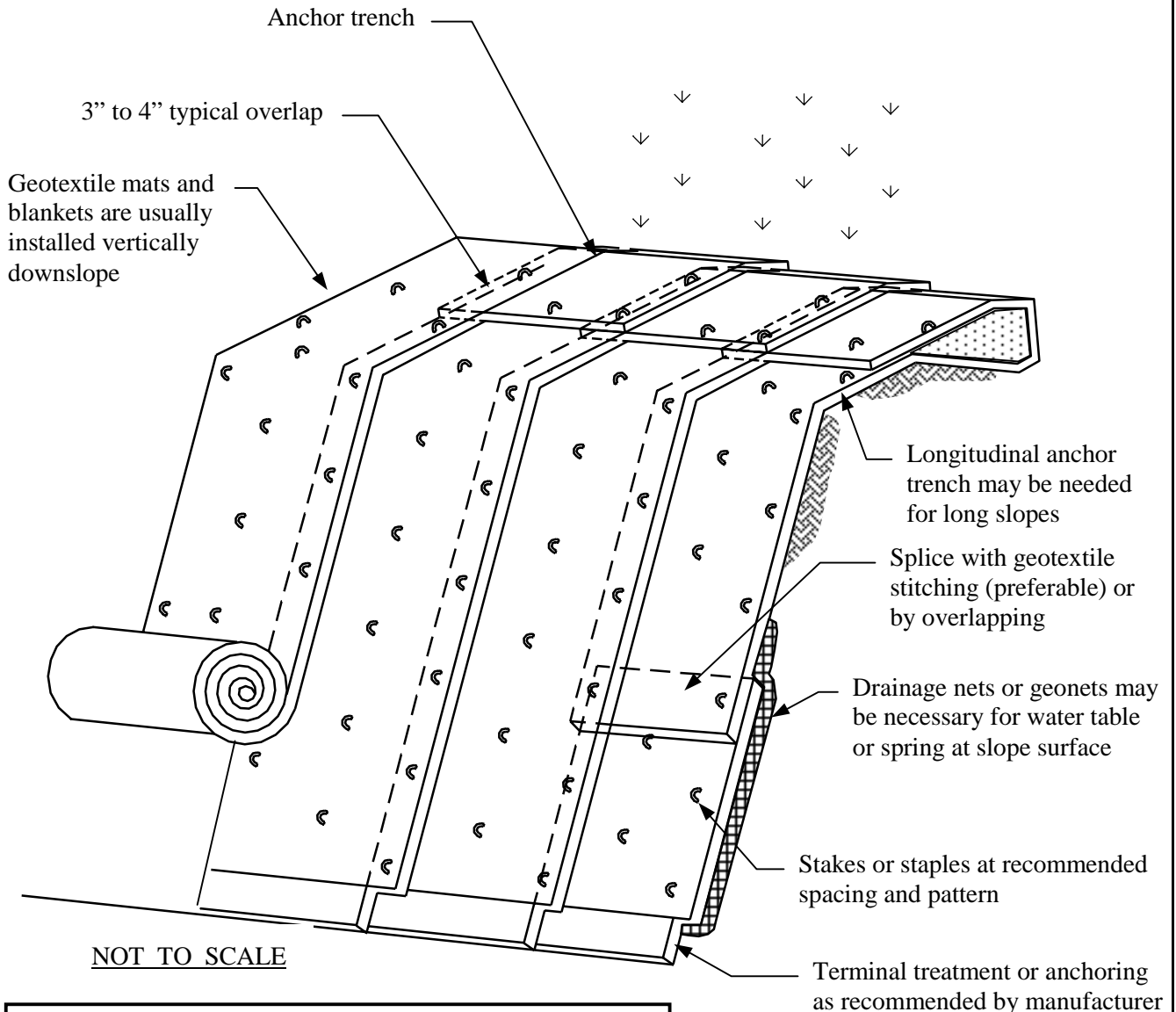

**Notes:**

1. Stitching geotextile seams is preferable to joints by overlapping. Consult a registered engineer for stability analysis of long grades or grades steeper than 3:1.
2. Staking or stapling layout shall conform to manufacturer's recommendations for flow and grades.

**Figure ES-12-2**  
**Anchoring Geotextiles on Embankments**

Install fiber roll along level contour,  
30' typical spacing

Install fiber roll on stream  
bank or top of steep slope

Wooden stakes, typical 4' spacing

Slope break or top  
of streambank

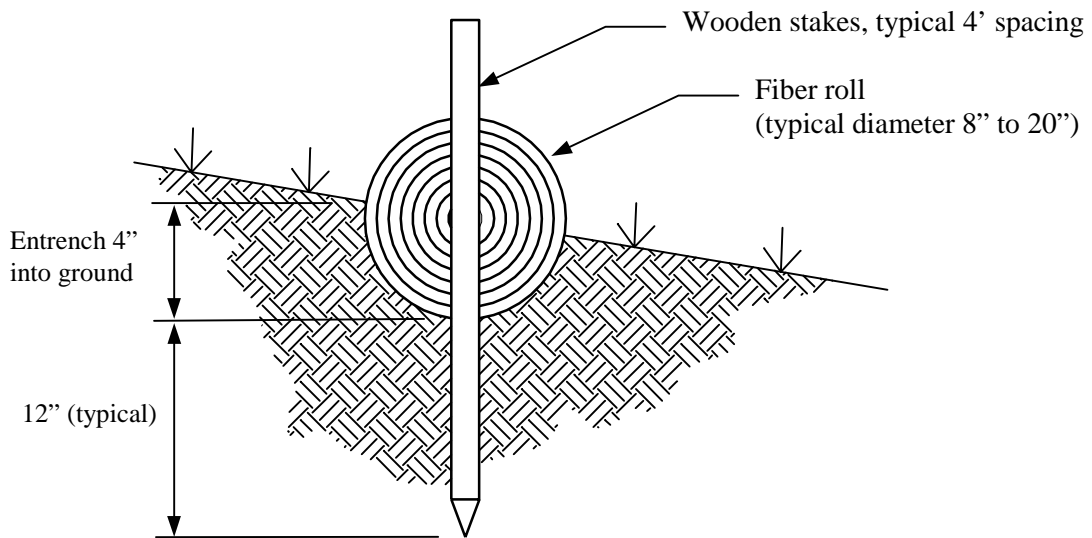

NOT TO SCALE

**Figure ES-12-3  
Fiber Roll Installation**